

## LM Guide GSR - Interchangeable self-adjusting type

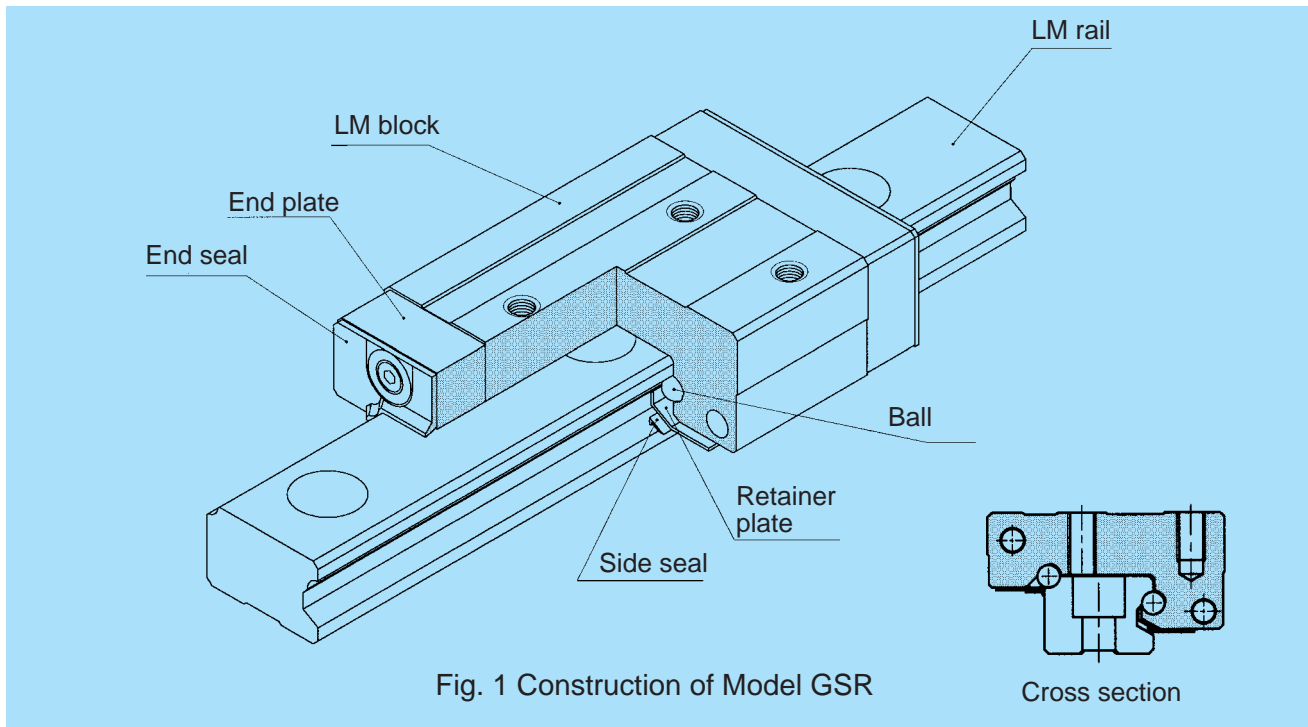

### Construction and Features

Balls roll in two rows of precision-ground raceway on an LM rail and an LM block. The end plate attached to the LM block causes the trains of balls to circulate. As the balls are held in place by the retainer plate, they do not fall off if the LM block is removed from the rail.

As the LM-block top surface is tilted, by simply fastening the mounting bolts, clearances can be eliminated and an appropriate preload can be applied.

As type GSR has a special contact design employing a circular-arc groove, even if levelness and rail parallelism are not fully established, it can provide smooth linear motion with no affect on service life. With its high self-adjusting capability, type GSR is best suited for uses in which high installation accuracy is difficult to achieve, and in industrial machines in general.

#### Interchangeability

The LM rail and block of this type are interchangeable with one another. As a result, rails and blocks can be stored separately. It is even possible to cut a long LM rail to a desired length and couple it with any LM block.

#### Bears loads in all directions

The ball-contact angle is designed to bear loads in all directions. Type GSR is therefore applicable where moments can act in any direction, including reverse-radial and lateral.

#### Compact

Type GSR is designed to be as low-profile as possible. This enables it to provide stable linear motion and keep the center of gravity low, making it possible to construct compact machine systems.

## Types and Features

### Type GSR-T (with a standard block)

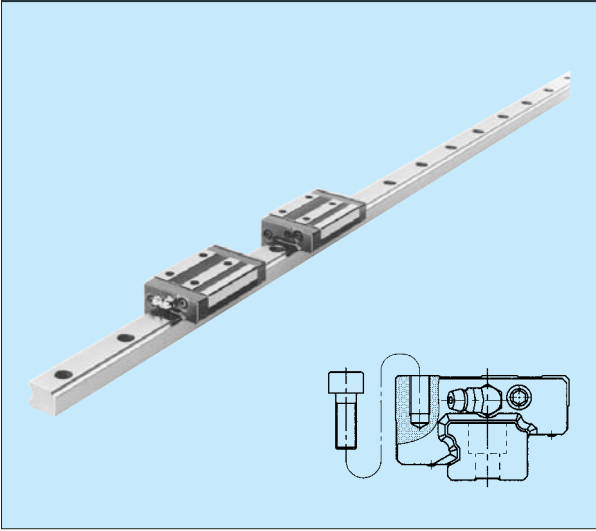

With large-diameter balls arranged in two rows of circular-arc grooves. Features an excellent self-adjusting capability, enabling it to compensate for mounting-surface errors, thereby ensuring smooth linear motion.

### Type GSR-V (with short block)

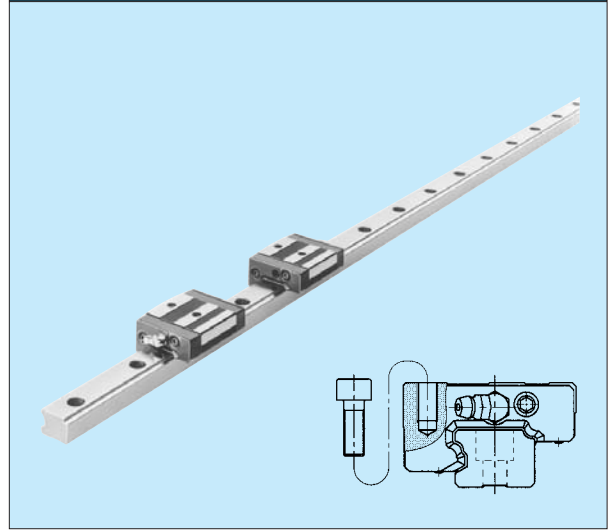

Type GSR-T modified by shortening the LM block; therefore space-saving

## Load Rating and Permissible Moment in Various Directions

### Load rating

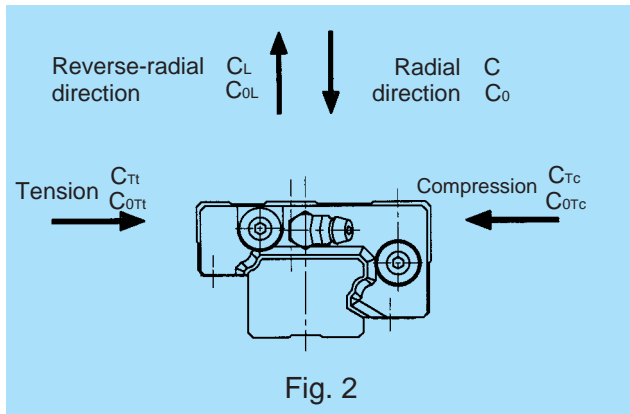

Fig. 2

Type GSR can bear loads in all four directions: radial, reverse-radial, and the two lateral directions.

The basic load rating is for a load in the radial direction on one LM block in the diagram shown above. The values are given in the corresponding dimension tables. Values for the reverse-radial, tensile, and compressive lateral directions are given in Table 1.

Table 1 Type-GSR Load Ratings in Various Directions

Direction	Basic dynamic load rating	Basic static load rating
Radial	$C$	$C_0$
Reverse-radial	$C_L=0.93C$	$C_{OL}=0.90C_0$
Tensile lateral	$C_{TL}=0.84C$	$C_{0TL}=0.78C_0$
Compressive lateral	$C_{Tc}=0.93C$	$C_{0Tc}=0.90C_0$

### Equivalent load

The equivalent load for type GSR when loads in the radial, tensile lateral, reverse-radial, and compressive lateral directions are exerted on its LM block simultaneously can be obtained using the following equation:

$$P_E = X \cdot P_R + Y \cdot P_{TL}$$

$$P_E = P_L + P_{TC}$$

where

$$P_E : \text{equivalent load} \quad (N)$$

- In the radial direction

- In the reverse-radial direction

- In the tensile lateral direction

- In the compressive lateral direction

$$P_R : \text{radial load} \quad (N)$$

$$P_L : \text{reverse-radial load} \quad (N)$$

$$P_{TL} : \text{tensile lateral load} \quad (N)$$

$$P_{TC} : \text{compressive lateral load} \quad (N)$$

X and Y : equivalent factor

Table 2 Type-GSR Equivalent Factor (under radial and tensile lateral loads)

$P_E$	X	Y
Equivalent load in the radial direction	1	1.280
Equivalent load in the tensile lateral direction	0.781	1

## Permissible moment

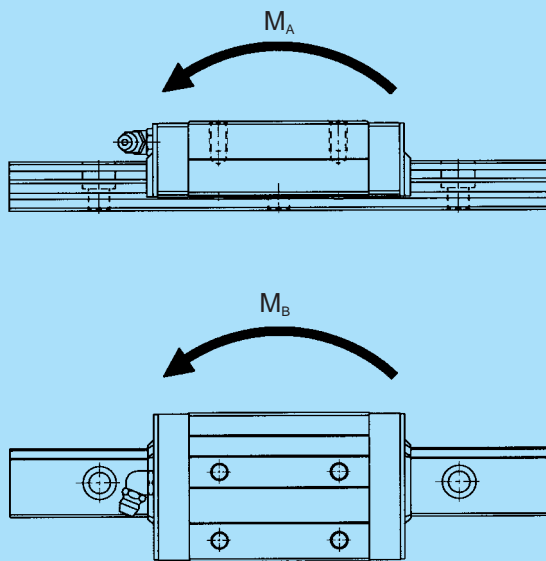

Fig. 3

In type GSR, a single LM block can bear moments in directions  $M_A$  and  $M_B$ . The moment in direction  $M_C$  can be applied if the LM Guide system uses two LM rails in parallel. Table 3 gives the permissible moments in directions  $M_A$  and  $M_B$  for a single LM block. The data on permissible moments in direction  $M_C$  is omitted here, as the moment depends on the distance between two rails.

Table 3 Type-GSR Static Permissible Moment

Unit : N•m

Model No.	$M_A$	$M_B$
GSR 15T	38.9	33.7
GSR 15V	18.2	15.7
GSR 20T	76.2	66.0
GSR 20V	35.8	31.0
GSR 25T	132	114
GSR 25V	61.5	53.3
GSR 30T	208	180
GSR 35T	311	270

# Accuracy Standards

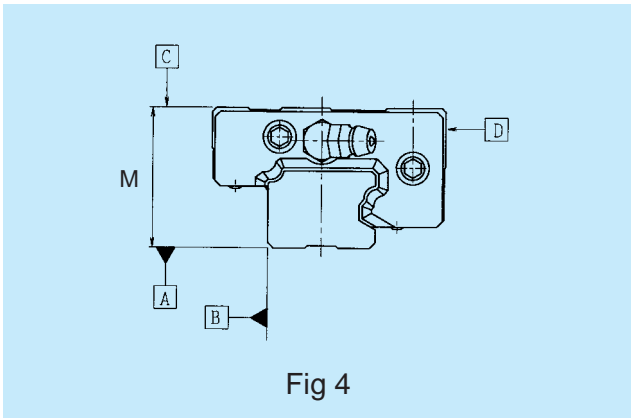

The accuracy of type GSR is shown in Table 2 for each model number, classified into the normal, high, and precision grades.

Table 4 Type GSR Accuracy Standard

Unit : mm

Model No.	Accuracy standard	Normal	High	Precision
	Item	No symbol	H	P
GSR 15 GSR 20	Tolerance for height M		±0.02	
	Running Parallelism of surface C with surface A		C (as per Fig. 5)	
	Running parallelism of surface D with surface B		D (as per Fig. 5)	
GSR 25 GSR 30 GSR 35	Tolerance for height M		±0.03	
	Running Parallelism of surface C with surface A		C (as per Fig. 5)	
	Running parallelism of surface D with surface B		D (as per Fig. 5)	

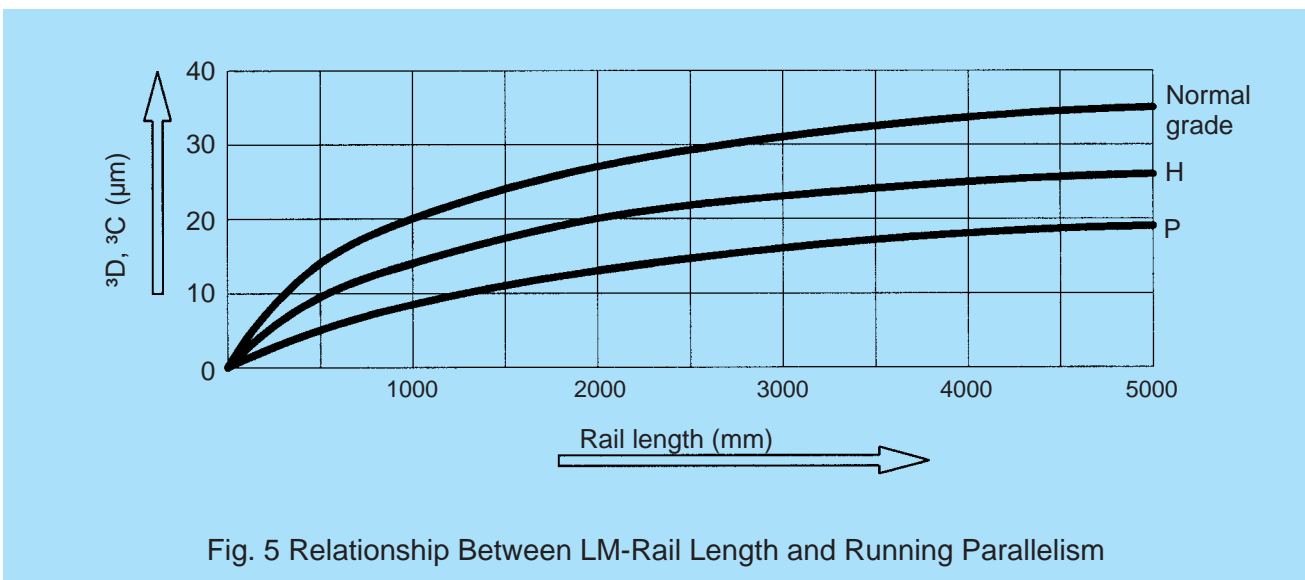
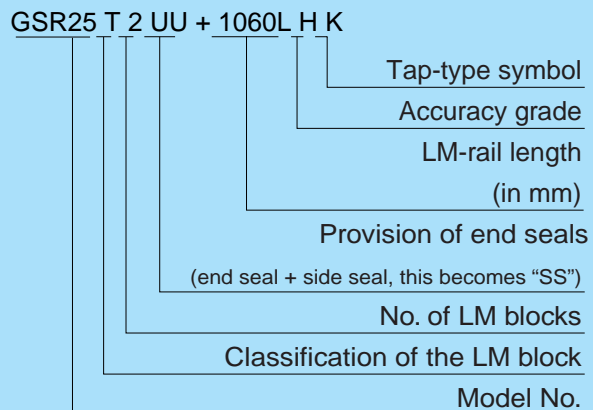

Fig. 5 Relationship Between LM-Rail Length and Running Parallelism

## Model-number coding

LM-rail/block combination model number



LM-block model number

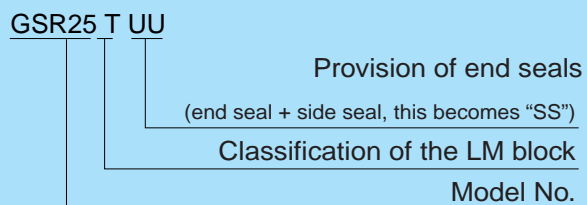

LM-rail model number

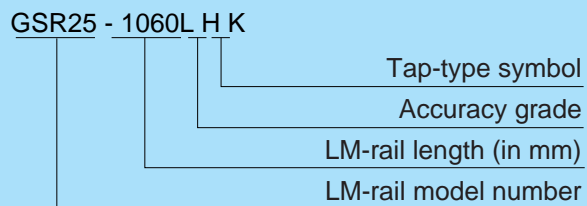

## Contamination Protection

From our wide array of products for type GSR, you can select the one best suited for your situation. (For details on seals, see “Contamination Protection” for type HSR on page A-223.)

If your choice is applicable to your system, please note that in some models, attaching a contamination-protection accessory to an LM block changes the block’s overall length. Add the increment specified in the corresponding dimension table to dimension L.

Table 5 Applicability of Seals to Type GSR, and the Increment to Be Added to the Block Overall Length

Unit : mm

Model No.	No symbol		UU		SS		DD		ZZ		KK	
	O	-	O	-	O	-	O	-	O	-	O	-
GSR 15	O	-4.8	O	-	O	-	O	5.0	O	6.8	O	11.8
GSR 20	O	-6.0	O	-	O	-	O	6.6	O	3.6	O	10.2
GSR 25	O	-7.0	O	-	O	-	O	7.0	O	3.6	O	10.6
GSR 30	O	-7.0	O	-	O	-	O	7.6	O	4.2	O	11.8
GSR 35	O	-7.0	O	-	O	-	O	7.6	O	4.2	O	11.8

Note: O = Applicable

### Seal resistance

The maximum values for seal resistance per LM block in type GSR...UU with a lubricant applied are given in Table 6.

Table 6 Maximum Resistance Value of seals to Type GSR

Unit : N

Model No.	Seal resistance value
GSR 15	2.5
GSR 20	3.1
GSR 25	4.4
GSR 30	6.3
GSR 35	7.6

## Mounting Procedures

LM Guide type GSR can be mounted by the procedure specified below.

1. Hold the table against the LM-block reference surface. Fully fasten bolts. The table must have a reference section on both sides.

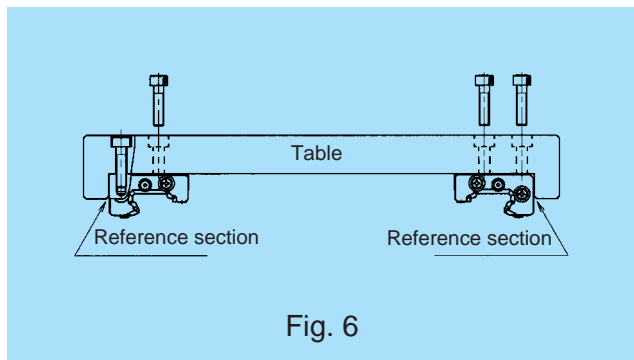

2. Position LM rail A on the base along a straight edge. Using a torque wrench, fully fasten the rail.

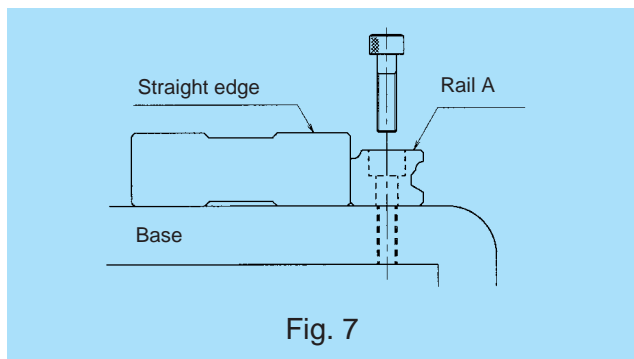

3. Temporarily fasten LM rail B to the base. Insert a block into the rail. With pressing LM rail B against the block, temporarily fasten the bolts.

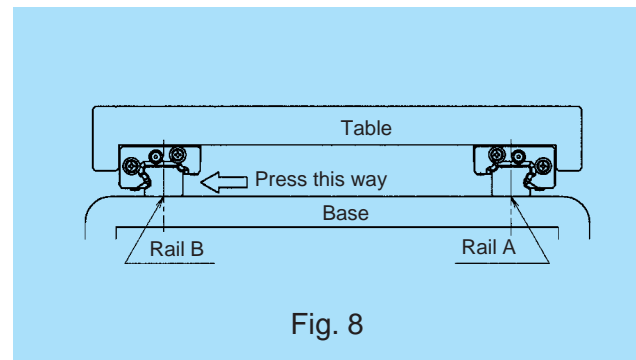

4. Move the table a couple of strokes. Break in the LM block on the rails. Using a torque wrench, fully fasten LM rail B.

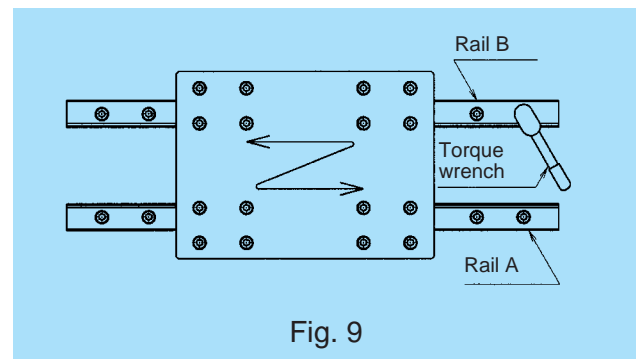

If multiple sets are to be mounted, prepare a jig as shown. The jig facilitates the establishment of parallelism between LM rails.

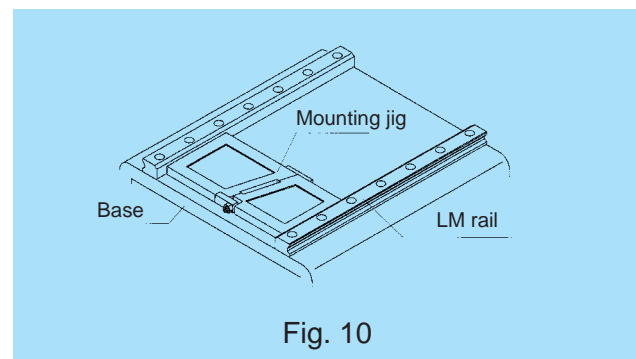



## Sample adjustment of clearance

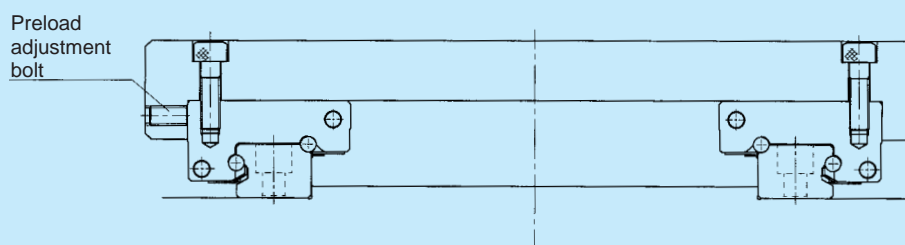

To increase rigidity, a reference section can be installed on the outer side of each LM block. By pressing the blocks sideways with set screws, a preload is exerted on the guideway, thereby increasing rigidity.

Fig. 11 Sample Preload Adjustment Using Set Screws

## Precautions on Use

### Mounting-Surface Height and Corner Profile

Normally, mounting surfaces for LM blocks and rails have lateral reference surfaces to aid in positioning rails and blocks with a high degree of accuracy.

For the reference-surface shoulder height, see Table 7.

Furthermore, provide enough space to the corner profile of a mounting surface so that the corner does not interfere with chamfers made on the LM blocks or rails, or provide the corner with a radius smaller than corner radius  $r$  specified in Table 7.

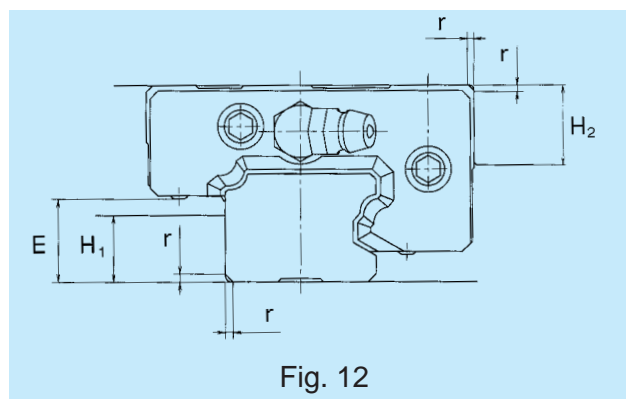

Fig. 12

Table 7 Mounting-Surface Shoulder Height and Corner Radius

Unit : mm

Model No.	Corner radius $r$ (max.)	LM-rail shoulder height $H_1$	LM-block shoulder max. height $H_2$	E
GSR 15	0.6	7	7	8
GSR 20	0.8	9	8	10.4
GSR 25	0.8	11	11	13.2
GSR 30	1.2	11	13	15
GSR 35	1.2	13	14	17.5

## LM-Rail Standard and Maximum Lengths

Table 8 gives the standard and maximum LM-rail lengths for type GSR.

If many rails of different lengths are used, it is

economical to stock LM rails of the maximum length, as they can be cut to the desired lengths in accordance with the necessary number of strokes.

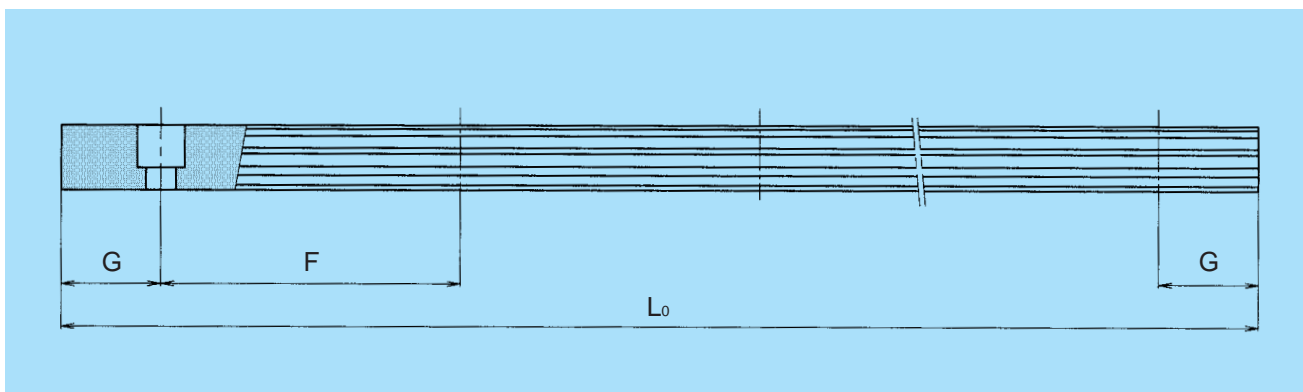

Table 8 Type-GSR LM-Rail Standard and Maximum Lengths

Unit : mm

Model No.	GSR 15	GSR 20	GSR 25	GSR 30	GSR 35
LM-rail standard length ( $L_0$ )	460	460	460	1240	1240
	820	820	820	1720	1720
	1060	1060	1060	2200	2200
	1600	1600	1600	3000	3000
Standard pitch F	60	60	60	80	80
G	20	20	20	20	20
Max. length	2000	3000	3000	3000	3000

### Tapped-hole LM rail type GSR-K

- The LM-rail bottom surface is provided with tapped holes, whereby H-shapes, channels, and similar steel materials can easily be attached.
- Because there are no mounting holes on the LM-rail surface, no foreign matter (e.g., cutting chips) can enter the system, resulting in improved sealability.

- Set a bolt length that will ensure a clearance of 2 to 3 mm at the tip of each bolt when the bolt is tightened over the full length of the effective tapped thread.
- We can also provide tapered washers that can be attached to steel shapes as shown in Fig. 13.
- For the model-number coding, see page A-289.

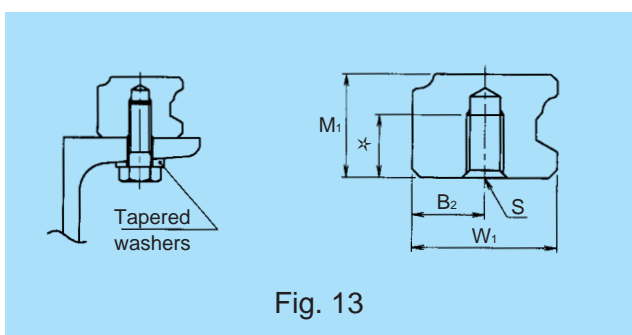
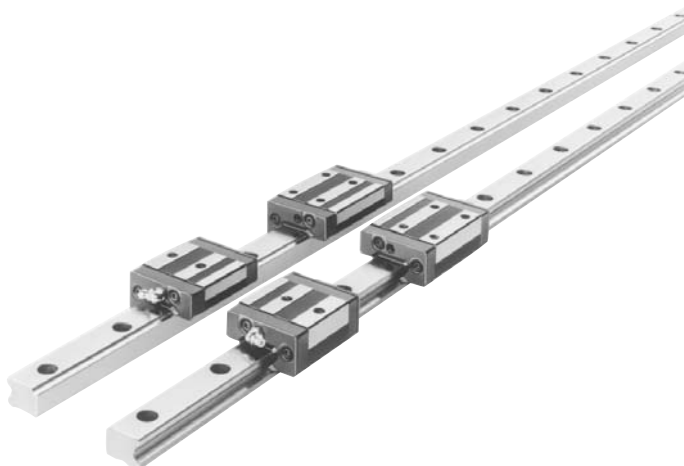

Fig. 13

Table 9 Tapped-Hole Position and Depth

Model No.	$W_1$	$B_2$	$M_1$	$S \times \ell$
GSR 15	15	7.5	11.5	M4 × 0.7 × 7
GSR 20	20	10	13	M5 × 0.8 × 8
GSR 25	23	11.5	16.5	M6 × 10
GSR 30	28	14	19	M8 × 12
GSR 35	34	17	22	M10 × 14

**Type GSR-T (long type)**  
**Type GSR-V (short type)**



Model No.	External dimensions			LM-block dimensions										
	Height M	Width W	Length L	B	B <sub>1</sub>	C	N-S × ℓ	K <sub>1</sub>	K <sub>2</sub>	L <sub>1</sub>	N <sub>1</sub>	N <sub>2</sub>	E	
GSR 15 T GSR 15 V	20	32	60 47.1	15	5	26 -	4-M4 × 0.7 × 7 2-M4 × 0.7 × 7	12	17.5	40.2 27.5	4.5	3	5.5	
GSR 20 T GSR 20 V	24	43	74 58.1	20	7	30 -	4-M5 × 0.8 × 8 2-M5 × 0.8 × 8	13.6	20.6	50.2 34.3	5	-	12	
GSR 25 T GSR 25 V	30	50	88 69	23	7	40 -	4-M6 × 10 2-M6 × 10	16.8	25.5	60.2 41.2	7	-	12	
GSR 30T	33	57	103	26	8	45	4-M8 × 12	18	28.5	70.3	7	-	12	
GSR 35T	38	68	117	32	9	50	4-M8 × 15	20.5	32.5	80.3	8	-	12	

Notes:

- For model-number coding, see page A-289.
- For permissible static moments  $M_A$  and  $M_B$ , see page A-287.

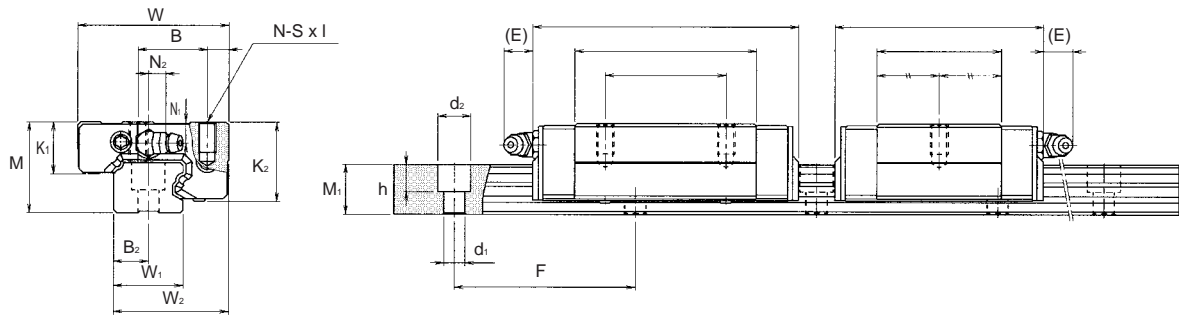

Unit : mm

Grease nipple	LM-rail dimensions						Basic load rating		Mass	
	Width $W_1$	$W_2$	$B_2$	Height $M_1$	Pitch $F$	$d_1 \times d_2 \times h$	C kN	$C_0$ kN	LM block kg	LM rail kg/m
PB-107	15	25	7.5	11.5	60	$4.5 \times 7.5 \times 5.3$	5.69 4.31	8.43 5.59	0.13 0.08	1.2
B-M6F	20	33	10	13	60	$6 \times 9.5 \times 8.5$	9.22 7.01	13.2 8.82	0.25 0.17	1.8
B-M6F	23	38	11.5	16.5	60	$7 \times 11 \times 9$	13.5 10.29	19.0 12.65	0.5 0.29	2.6
B-M6F	28	44.5	14	19	80	$9 \times 14 \times 12$	18.8	25.9	0.6	3.6
B-M6F	34	54	17	22	80	$11 \times 17.5 \times 14$	25.1	33.8	1.0	5.0

- For standard LM-rail lengths, see page A-293.

## Rack-toothed LM Guide Type GSR-R

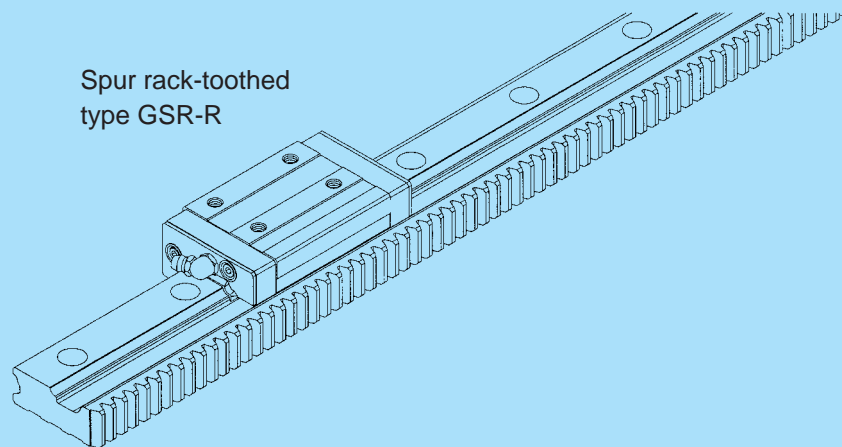

Fig. 1 Construction of type GSR-R

### Construction and Features

Balls roll in two rows of precision-ground raceway on an LM rail and an LM block. The end plate attached to the LM block causes the trains of balls to circulate. As the balls are held in place by the retainer plate, they do not fall off if the LM block is removed from the rail.

As the LM-block top surface is tilted, by simply fastening the mounting bolts, clearances can be eliminated and an appropriate preload can be applied.

Type GSR-R is a modification of type GRS, with the rack teeth cut on the LM rail. This aids in the design and assembly of drive mechanisms.

#### Reduces working and assembly costs

The one-piece structure integrating the LM rail (linear guide) and rack (drive) reduces the man-hours required to work the mounting surface for receiving a rack, and to attach it to the rail. This substantially reduces overall costs.

#### Facilitates design

The displacement per turn of the pinion is in increments of integral multiples. This makes it easy to calculate the displacement per pulse when the LM Guide is used in combination with a stepping or servo motor.

#### Space-saving

The rack and the LM rail are formed into one unit. As a result, a system using this type of LM Guide can be made compact in size.

#### Free stroke

The LM-rail end faces are finished for connected use. To obtain a rail for use with long strokes, simply connect LM rails of the standard length.

#### High durability

The rack-tooth width is equal to the LM-rail height. The material is high-grade steel with proven high performance, and the rack teeth are heat-treated, thereby ensuring the high durability of type GSR-R.

## Types and Features

### Type GSR-R (with a rack-toothed LM rail)

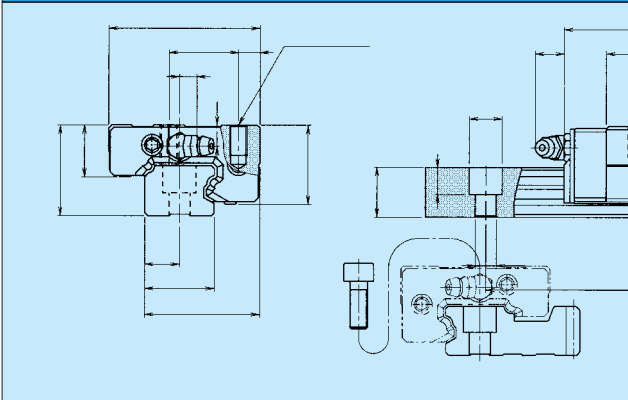

#### ■ Can be used if the pinion mounting part does not have high rigidity

As the thrust load on the pinion shaft can be kept low due to rack-pinion meshing, it is easy to design systems with pinion shaft bearings and tables that are not high in rigidity.

## Load Rating and Permissible Moment in Various Directions

### Load rating

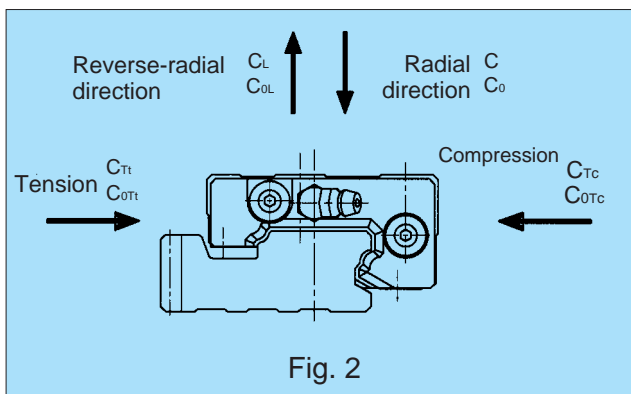

Type GSR-R can bear loads in all four directions: radial, reverse-radial, and the two lateral directions.

The basic load rating is for a load in the radial direction on one LM block in the diagram shown above. The values are given in the corresponding dimension tables. Values for the reverse-radial, tensile, and compressive lateral directions are given in Table 1.

Table 1 Type-GSR-R Load Ratings in Various Directions

Direction	Basic dynamic load rating	Basic static load rating
Radial	C	$C_o$
Reverse-radial	$C_L = 0.93C$	$C_{oL} = 0.90C_o$
Tensile lateral	$C_{Tt} = 0.84C$	$C_{oTt} = 0.78C_o$
Compressive lateral	$C_{Tc} = 0.93C$	$C_{oTc} = 0.90C_o$

## Equivalent load

The equivalent load for type GSR-R when loads in the radial, tensile lateral, reverse-radial, and compressive lateral directions are exerted on its LM block simultaneously can be obtained using the following equation:

$$P_E = X \cdot P_R + Y \cdot P_{Tl}$$

$$P_E = P_L + P_{TC}$$

where

$P_E$  : equivalent load (N)

- In the radial direction
- In the reverse-radial direction
- In the tensile lateral direction
- In the compressive lateral direction

$P_R$  : radial load (N)

$P_L$  : reverse-radial load (N)

$P_{Tl}$  : tensile lateral load (N)

$P_{TC}$  : compressive lateral load (N)

X and Y : equivalent factor

Table 2 Type-GSR-R Equivalent Factor (under radial and tensile lateral loads)

$P_E$	X	Y
Equivalent load in the radial direction	1	1.280
Equivalent load in the tensile lateral direction	0.781	1

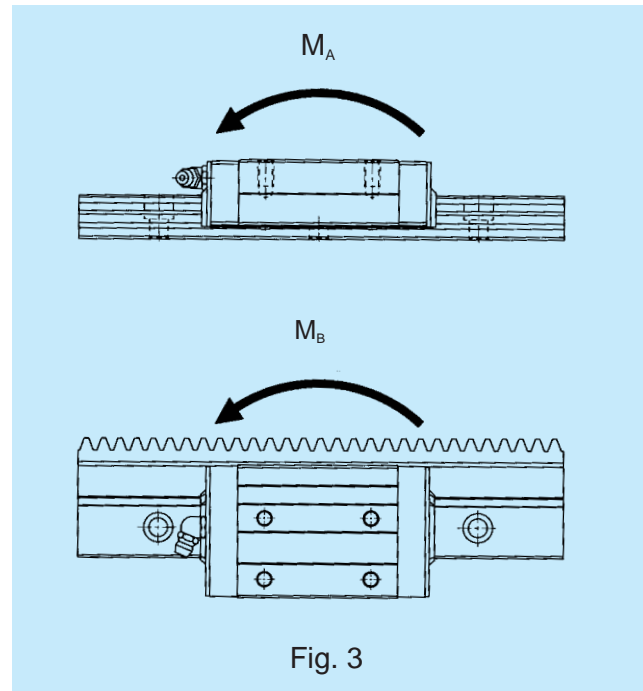

In type GSR-R, a single LM block can bear moments in directions  $M_A$  and  $M_B$ . The moment in direction  $M_C$  can be applied if the LM Guide system uses two LM rails in parallel. Table 3 gives the permissible moments in directions  $M_A$  and  $M_B$  for a single LM block. The data on permissible moments in direction  $M_C$  is omitted here, as the moment depends on the distance between two rails.

Table 3 Type-GSR-R Static Permissible Moment

Unit : N·m

Model No.	$M_A$	$M_B$
GSR 25 T-R	132	114
GSR 25 V-R	61.5	53.3
GSR 30 T-R	208	180
GSR 35 T-R	311	270

## Accuracy Standards

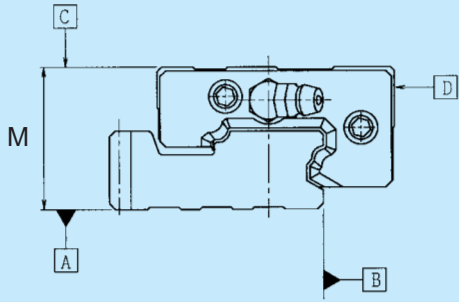

Fig. 4

The accuracy of type GSR-R is shown in Table 4 for each model number, classified into the normal and high grades.

Table 4 Type GSR-R Accuracy Standard

Unit : mm

Model No.	Accuracy standard	Normal	High
	Item	No symbol	H
GSR 25 GSR 30 GSR 35	Tolerance for height M	±0.03	
	Running Parallelism of surface C with surface A	C (as per Fig. 5)	
	Running parallelism of surface D with surface B	D (as per Fig. 5)	

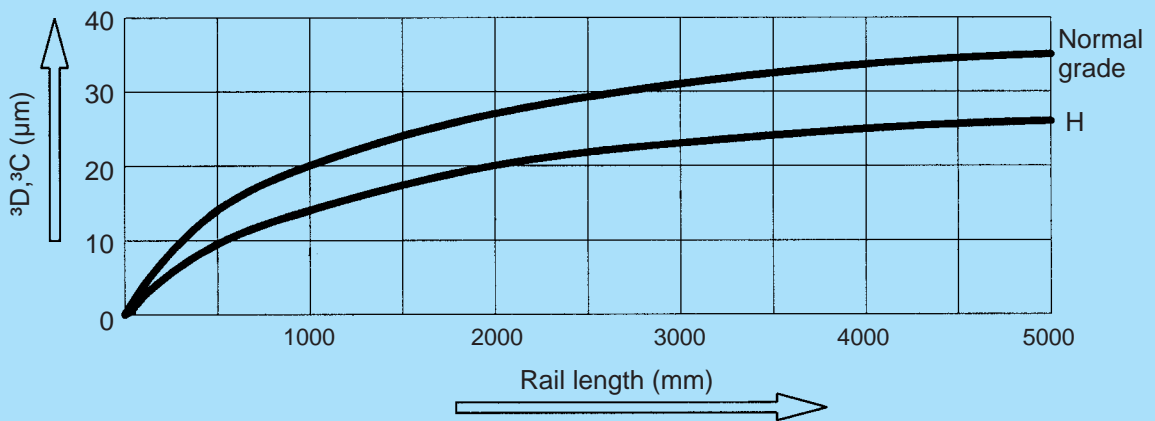
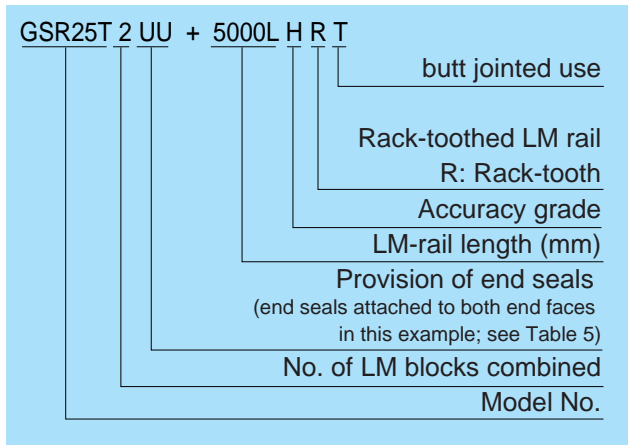

Fig. 5 Relationship Between LM-Rail Length and Running Parallelism



## Model-number coding

### One-Axis LM Guide



\* If LM rails of various lengths are to be put to butt jointed use, contact us.

Note: One model number in this example is required for one LM Guide in a one-axis configuration.

### Separate-part model number

#### ● LM block model number

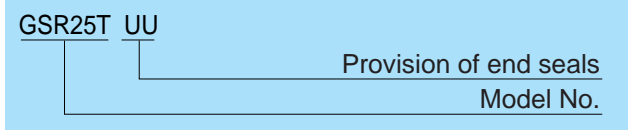

#### ● Rack-toothed-LM-rail model number

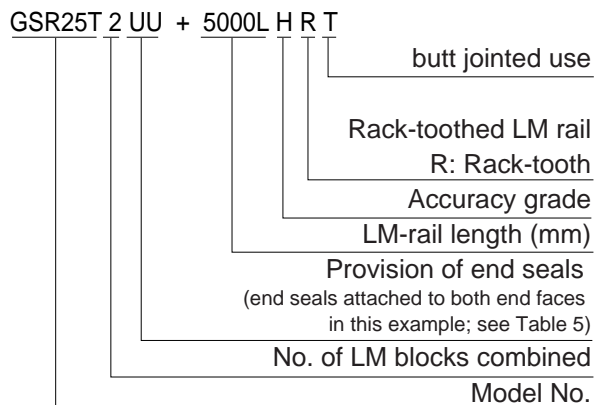
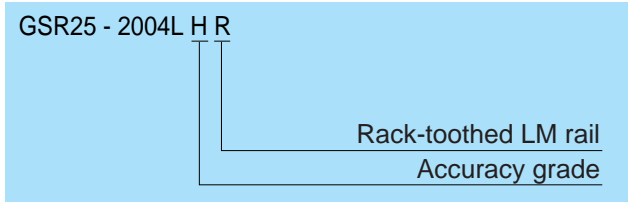

## Contamination Protection

### Seal resistance value

The maximum values for seal resistance per LM block in type G with a lubricant applied are given in Table 5.

Table 5 Maximum Resistance Value of seals to Type GSR-R  
Unit : N

Model No.	Seal resistance value
GSR 25R	4.4
GSR 30R	6.3
GSR 35R	7.6

From our wide array of products for type GSR-R, you can select the one best suited for your situation. (For details on seals, see “Contamination Protection” for type HSR on page A-223.)

Some models do not accept contamination-protection accessories. Confirm which parts are applicable by referring to Table 6.

If your choice is applicable to your system, please note that in some models, attaching a contamination-protection accessory to an LM block changes the block’s overall length. Add the increment specified in the corresponding dimension table to dimension L.

## Precautions on Use

### Mounting-Surface Height and Corner Profile

See Table 7, as the reference section is placed on the opposite side of the rail compared to its position in the standard type GSR.

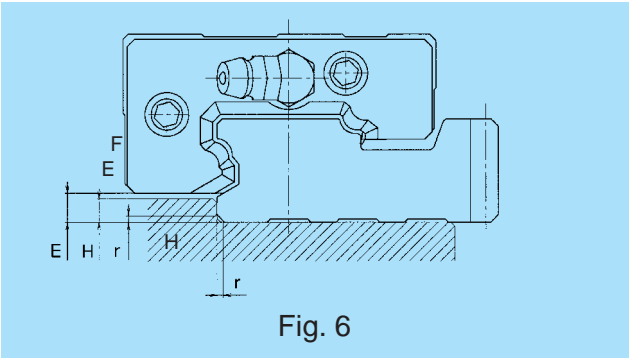

Fig. 6

Table 7 Mounting-Surface Shoulder Height and Corner Radius

Unit : mm

Model No.	Corner radius r (max.)	LM-rail shoulder height H	E
GSR 25	0.8	4	4.5
GSR 30	1.2	4	4.5
GSR 35	1.2	4.5	5.5

### Joint between rack teeth

The end faces of rack-toothed LM rails are finished so as to ensure a clearance that will aid in their connection.

Use of the special jig shown in Fig. 7 will make connection even easier. (We also offer a special jig for aligning rack teeth.)

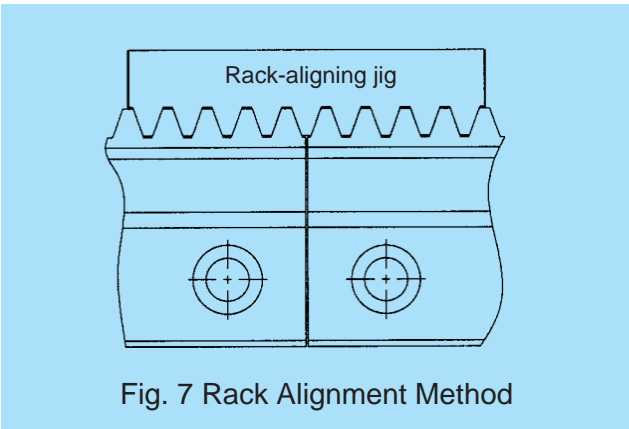

Fig. 7 Rack Alignment Method

### Reworking the pinion hole

Only the teeth of the pinion-hole-diameter reworking type (type C) are heat-treated. The hole and keyway can therefore be reworked by the user to the desired diameter and shape.

When carrying out reworking, be sure to take the following into consideration.

Material of the hole-diameter reworking type (type C): S45C

1. When chucking the teeth of a hole-diameter reworking-type pinion, use a jaw scroll chuck or similar tool so as to maintain the tooth profile.
2. The pinion is produced using the hole center as a reference point. The hole center should therefore be used as a reference point when the pinion is aligned. When checking the pinion run-out, refer to the boss sides.
3. Keep the reworked hole diameter within 60% to 70% of the boss diameter.

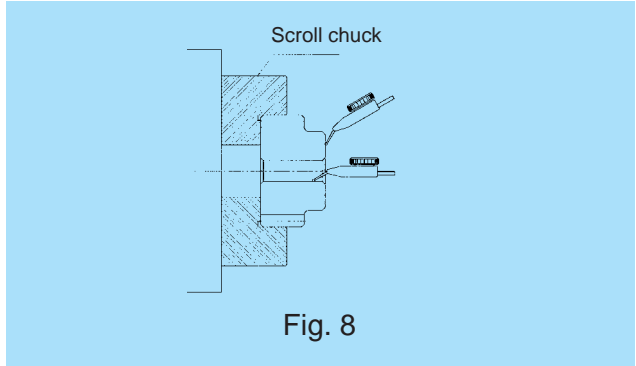

Fig. 8

### Lubricating the rack and pinion

To ensure smooth sliding on tooth surfaces and prevent wear, the teeth should be provided with a lubricant.

\* Use a lubricant of the same type as that sealed in the LM Guide.

## Checking strength

The strength of the assembled rack and pinion must be checked in advance.

1. Calculate the maximum thrust exerted on the pinion.
2. Divide the permissible power-transmission capacity of the pinion to be used (Table 8) by an overload factor (Table 9).
3. By comparing the thrust exerted on the pinion obtained in step 1 with the pinion power-transmission capacity obtained in step 2, make sure the loaded thrust is not greater than the permissible power-transmission capacity.

[Calculation example]

Type GSR-R is used in a horizontal conveyance system subjected to medium impact (assume external loads to be zero).

### Conditions

Subject model No. (pinion)	GP6-20A
Mass (table + work)	m = 100 kg
Velocity	v = 1 m/s
Acceleration/deceleration time	T <sub>1</sub> = 0.1 s

### Consideration

1. Obtain the maximum thrust  
Calculate the thrust during acceleration and deceleration

$$F_{\max} = m \cdot \frac{v}{T_1} = 1.00 \text{ kN}$$

2. Compare the maximum thrust with the pinion power-transmission capacity

$$P_{\max} = \frac{\text{Obtain the pinion power-transmission capacity}}{\text{Compare the maximum thrust with the pinion power-transmission capacity}} = \frac{2.33}{1.25} = 1.86 \text{ kN}$$

3. In this way, the applicability of the subject model number can be judged.

$$F_{\max} < P_{\max}$$

Table 8 Permissible Power-Transmission Capacity

Unit : kN

Model No.	Permissible power-transmission capacity	Applicable model No.
GP 6 - 20A	2.33	GSR 25 - R Type
GP 6 - 20C	2.05	
GP 6 - 25A	2.73	
GP 6 - 25C	2.23	
GP 8 - 20A	3.58	GSR 30 - R Type
GP 8 - 20C	3.15	
GP 8 - 25A	4.19	
GP 8 - 25C	3.42	
GP10 - 20A	5.19	GSR 35 - R Type
GP10 - 20C	4.57	
GP10 - 25A	6.06	
GP10 - 25C	4.96	

Table 9 Overload Factor

Impact from the driving side	Impact from the driven side		
	Uniform load	Medium impact	Heavy impact
Uniform load (motors, turbines, hydraulic motors, etc.)	1.0	1.25	1.75

(JGMA401-01)

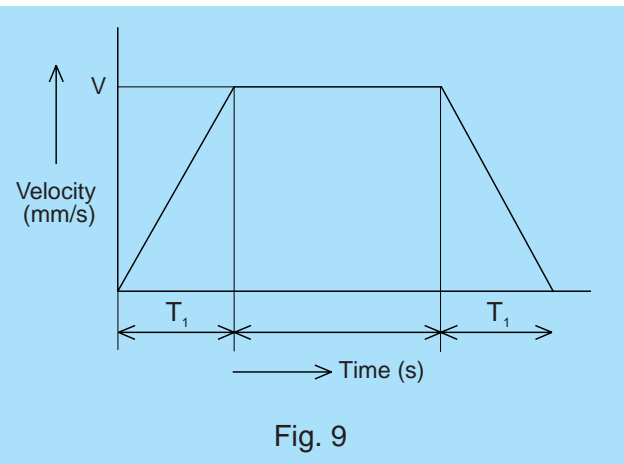
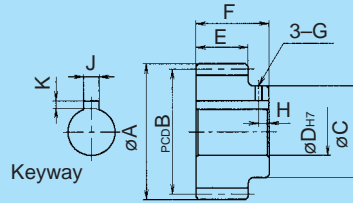

Fig. 9

## Pinion

### ● Pinion for racks (type A) Keyway working type



Unit : mm

Model No.	Pitch	No. of teeth	Tip circle diameter A	Meshing PCD B	Boss diameter C	Hole diameter D	Face width E	Overall length F	G	H	Keyway J × K	Applicable LM-Guide Model No.
GP 6-20A	6	20	42.9	39.0	30	18	16.5	24.5	M3	4	6 × 2.8	GSR25 R
GP 6-25A		25	51.9	48.0	35	18						
GP 8-20A	8	20	57.1	52.0	40	20	19	26	M3	5	8 × 3.3	GSR30 R
GP 8-25A		25	69.1	64.0	40	20			M4			
GP10-20A	10	20	70.4	64.0	45	25	22	30	M4	5	8 × 3.3	GSR35 R
GP10-25A		25	86.4	80.0	60	25					10 × 3.3	

- 1) When placing an order, specify the model numbers given in this table.
- 2) We can provide non-standard pinions with a different number of teeth. If you require them, contact us.

### ● Pinion for racks (type C) Hole-diameter reworking type

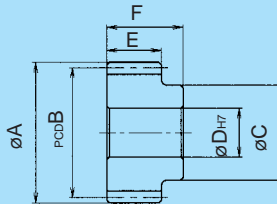

Unit : mm

Model No.	Pitch	No. of teeth	Tip circle diameter A	Meshing PCD B	Boss diameter C	Hole diameter D	Face width E	Overall length F	Applicable LM-Guide Model No.
GP 6-20C	6	20	42.9	39.0	30	12	16.5	24.5	GSR25 R
GP 6-25C		25	51.9	48.0	35	15		24.5	
GP 8-20C	8	20	57.1	52.0	40	18	19	26	GSR30 R
GP 8-25C		25	69.1	64.0	40	18		26	
GP10-20C	10	20	70.4	64.0	45	18	22	30	GSR35 R
GP10-25C		25	86.4	80.0	60	18		30	

- 1) When placing an order, specify the model numbers given in this table.
- 2) We can provide non-standard pinions with a different number of teeth. If you require them, contact us.

## LM-Rail Standard and Maximum Lengths

The LM-rail standard lengths of rack-toothed LM Guide type GSR-R are shown in Table 10

As LM rails of type GSR-R are provided with a special end-face finish, they can be connected without further working.

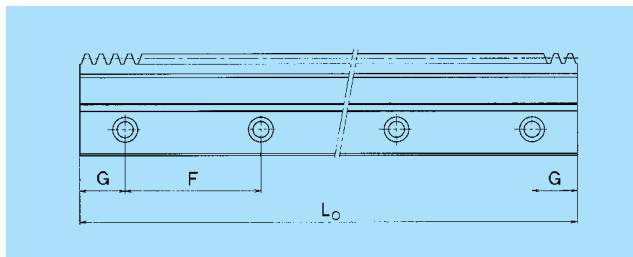
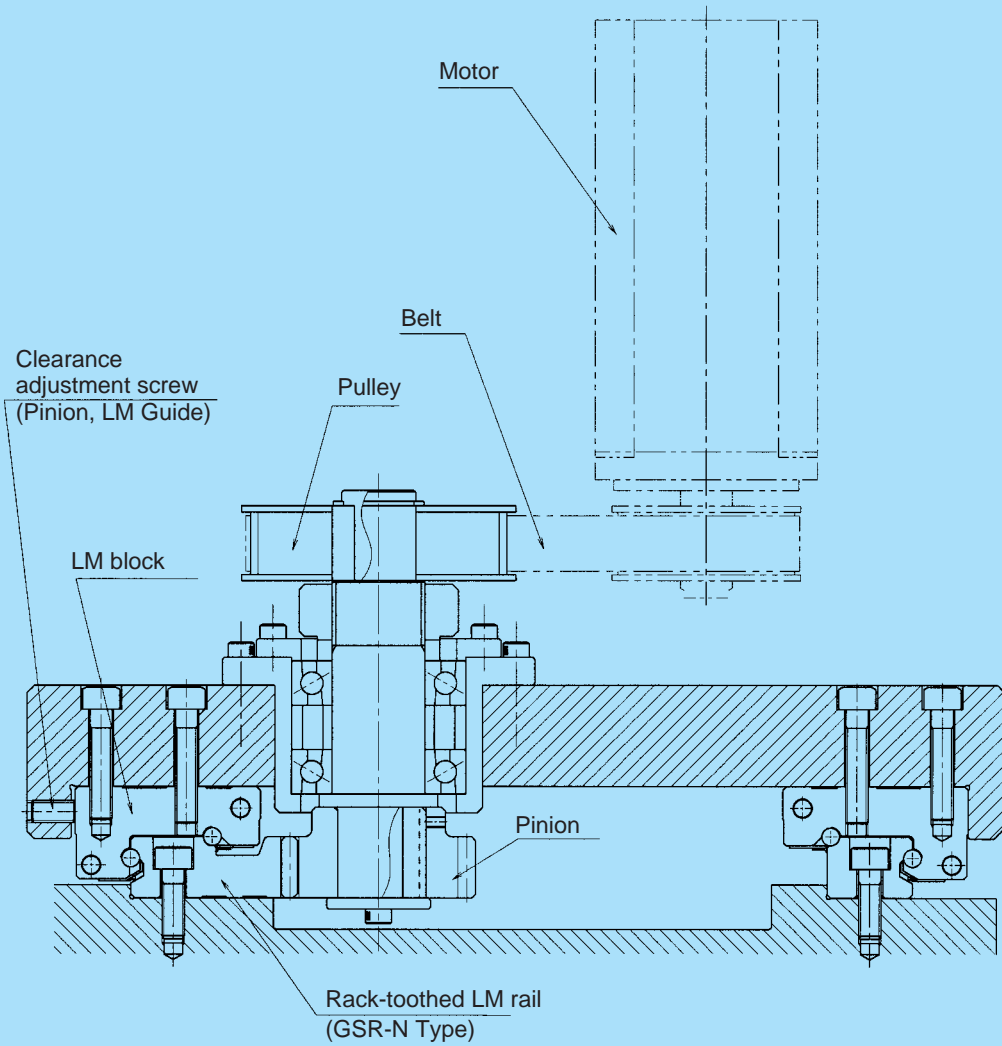
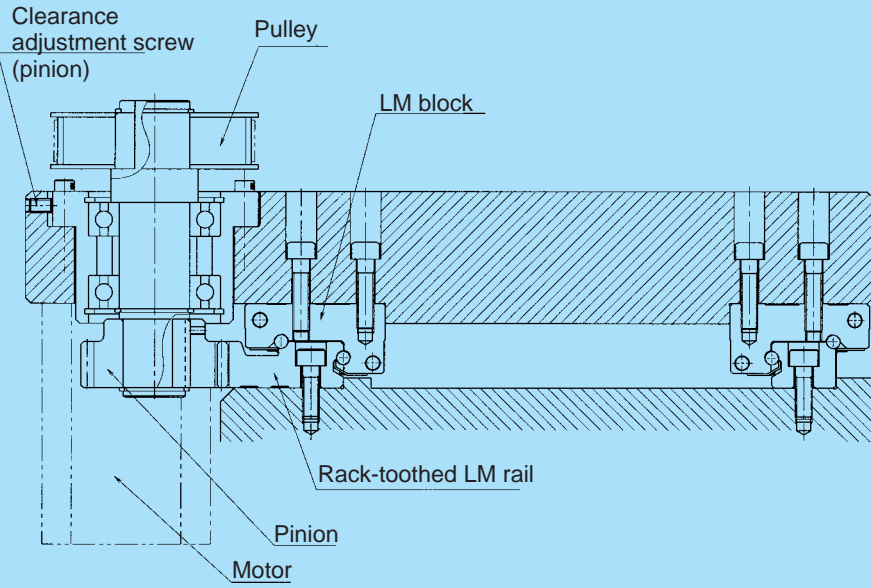

Table 10 Type-GSR-R LM-Rail Standard and Maximum Lengths

Unit : mm

Model No.	LM-rail standard length ( $L_0$ )	Standard pitch F	G
GSR 25 - R	1500	60	30
	2004		42
GSR 30 - R	1504	80	32
	2000		40
GSR 35 - R	1500	80	30
	2000		40

# Sample table assembly



## Rack-Toothed LM Guide Type GSR-R

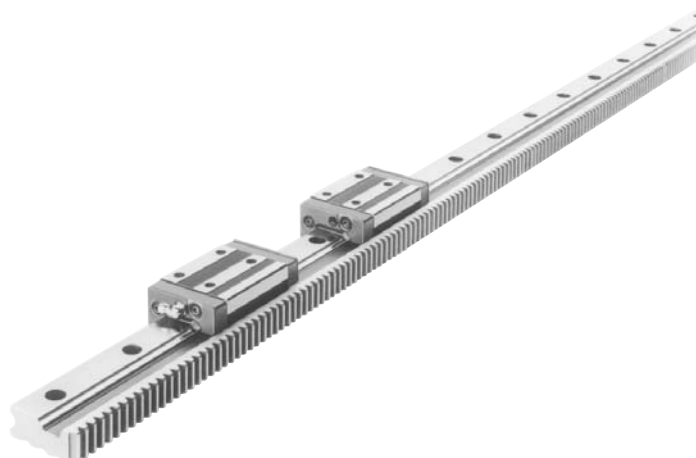

Model No.	Reference pitch P	Module	Pitch line height E	External dimensions			LM-block dimensions								
				Height M	Width W	Length L	B	C	B <sub>1</sub>	S × ℓ	W <sub>1</sub>	L <sub>1</sub>	K	T <sub>1</sub>	T <sub>2</sub>
GSR 25T - R GSR 25V - R	6	1.91	43	30	59.91	$\frac{88}{69}$	23	40	7	M6 × 10	50	$\frac{60.2}{41.2}$	25.5	9	13
GSR 30T - R	8	2.55	48	33	67.05	103	26	45	8	M8 × 12	57	70.3	28.5	10	15
GSR 35T - R	10	3.18	57	38	80.18	117	32	50	9	M8 × 15	68	80.3	32.5	12	16

### Notes:

- LM Guides with special modules and pitches can be manufactured. Please contact THK for further information.
- For model-number coding, see page A-300.
- For the procedure for checking pinion strength, see page A-302.

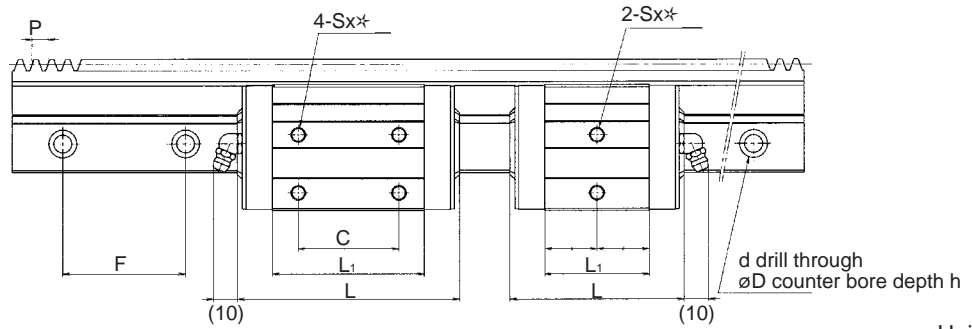
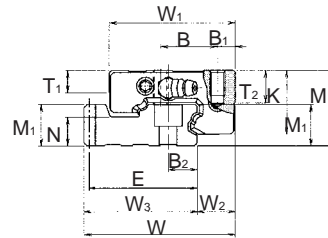

Unit : mm

Grease nipple	LM-rail dimensions							Basic load rating		Mass	
	Width $M_1$	$W_2$	$W_3$	$B_2$	N	$d \times D \times h$	F	C kN	$C_0$ kN	LM block kg	LM rail kg/m
B-M6F	16.5	15	44.91	11.5	11.5	$7 \times 11 \times 9$	60	13.5	19.0	0.5	4.7
								10.29	12.65	0.29	
B-M6F	19	16.5	50.55	14	12	$9 \times 14 \times 12$	80	18.8	25.9	0.6	5.9
B-M6F	22	20	60.18	17	14.5	$11 \times 17.5 \times 14$	80	25.1	33.8	1.0	8.1

- For LM-rail standard lengths, see page A-304.
- For static permissible moments  $M_A$  and  $M_B$ , see page A-298.



