

THK

NEW



High-Speed Ball Screw with Ball Cage Model SBK

Low noise, long-term maintenance-free operation
High speed, high accuracy
DN value: 160,000

SBK

Achieves high-speed feed at 114 m/min

*With model SBK4030



THK CO., LTD.
TOKYO, JAPAN

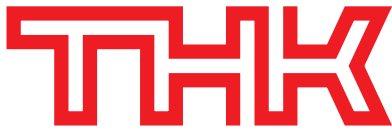

High-Speed Ball Screw with Ball Cage Model SBK **SBK**

Stress-free, ideal circulation structure

Circulate toward the tangential direction

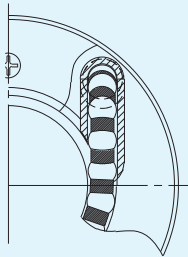

Circulate toward the lead-angle direction

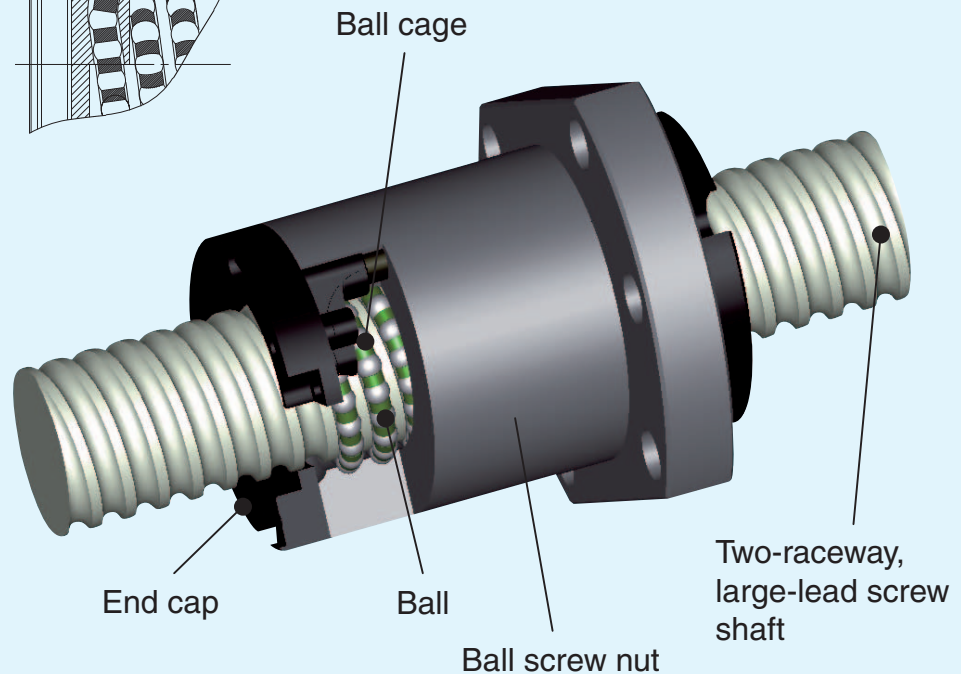
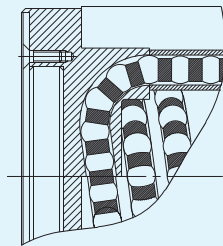

Fig. 1 Structural Drawing of Model SBK

Structure

With High-Speed Ball Screw with Ball Cage model SBK, balls are evenly spaced by a ball cage to eliminate collision and friction between the balls and ensure a high level of grease retention. As a result, low noise, low torque fluctuation and long-term maintenance-free operation are achieved.

In addition, this model has an ideal circulation structure where balls are picked up at the tangential direction (Fig. 2), thus to achieve a DN value* of 160,000 (* DN value = ball center diameter × rotation speed per minute) in high-speed operation.

As a result of adopting a method to provide a phase difference between the two raceways of the nut, its overall ball screw nut length is shorter and its body is more compact than the double-nut type, which uses the spacer-based preloading method.

Features

●Superbly high speed

Use of a circulation structure in which balls are picked up in the tangential direction and the lead-angle direction by end caps (Fig. 2) enables the Ball Screw to be used in high speed operation at a DN value of 160,000, thus to achieve high-speed feed 2.2 times faster than the conventional type.

●Smooth motion

Use of a ball cage eliminates friction between balls (Fig. 4) and minimizes torque fluctuation, thus allowing smooth motion to be achieved.

●Long-term maintenance-free operation

Increased grease retention through formation of grease pockets (Fig. 4) ensures long-term maintenance-free operation.

●Low noise, acceptable running sound

Use of a ball cage placed to prevent each ball from contacting the adjacent ball eliminates collision noise between the balls (Fig. 4). In addition, the circulation structure where balls are picked up at the tangential direction (Fig. 2) also contributes to eliminating collision noise generated from circulating balls and decreases a noise level.

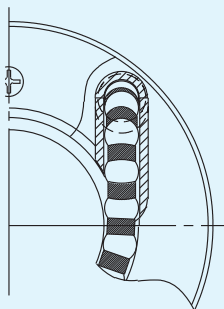

Fig .2

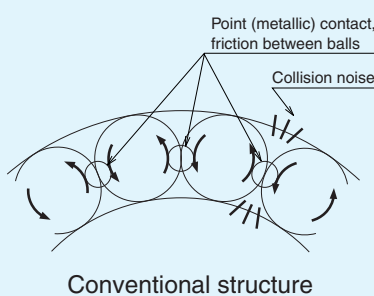

Fig. 3

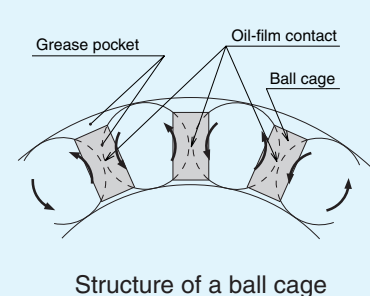

Fig. 4

■ Superbly high speed

Conditions

Sample	SBK4030-7.6
Rotation speed	3800(min^{-1}) (DN value: 160,000)
Stroke	700mm
Load	2.3kN
Acceleration	1G
Lubrication	Multemp HRL Grease + QZ Lubricator (oil grease)

Result

Normally operates after running 7,000 km without any anomaly.

■ Smooth motion

Conditions

Rotation speed	60 min^{-1}
Stroke	800mm
Lubrication	Multemp HRL Grease

SBK4030-7.6

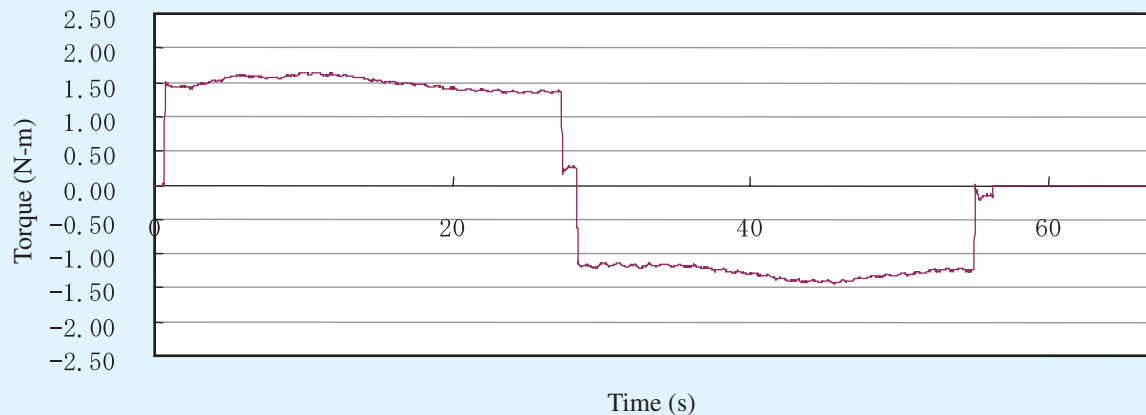

Lownoise

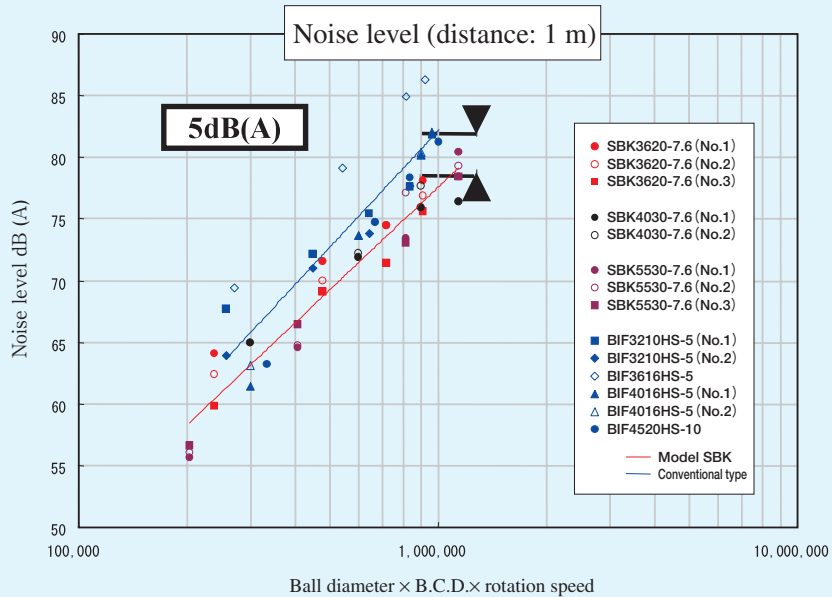

Result

A noise level 5 dB (A) lower than the conventional type is achieved.

Accuracy Standards

THK High-Speed Ball Screw with Ball Cage is manufactured with accuracy compliant with JISB1192 (precision Ball Screw). This model can be manufactured with up to the maximum accuracy of C0 grade. In terms of lead accuracy measurement, the lead accuracy is assured with a laser measurement machine, whose reliability is proven. For details of the standard values, see the General Catalog.

Static Safety Factor

Basic static load rating C_{0a}

If a Ball Screw receives an excessive load or a large impact load while it is stationary or in motion, local permanent deformation occurs between the raceway and the steel ball. If the permanent deformation exceeds a certain limit, it will prevent smooth motion.

It is established that in general, if the permanent deformation is approximately 0.0001 times the steel ball diameter, there is no problem in operation at all. The load applied here is called a basic static load rating C_{0a} . Depending on the service conditions, it is necessary to consider a static safety factor in the axial direction as indicated in table 1.

Static safety factor

$$f_s \geq \frac{C_{0a}}{F_a}$$

where

f_s : Static safety factor (table 1)

C_{0a} : Basic static load rating KN

F_a : Axial load KN

Table 1 Static Safety Factor

Machine used	Loading conditions	Lower limit of f_s
General industry machine	Without vibration/impact	1.0 to 1.3
	With vibration/impact	2.0 to 3.0
Machine tool	Without vibration/impact	1.0 to 1.5
	With vibration/impact	2.5 to 7.0

Rated Life and Service Life Time

Basic dynamic load rating Ca

The factor basic dynamic load rating Ca is used to calculate the service life of a Ball Screw when the ball screw nut operates under a load.

Basic dynamic load rating Ca refers to an axial load under which the rated load on 90% of a group of identical Ball Screw units independently operating is 10^6 rev (1 million revolutions).

Rated life

The service life of a Ball Screw is obtained from the following equation using the basic dynamic load rating and the axial load.

$$L = \left(\frac{Ca}{f_w \cdot Fa} \right)^3 \times 10^6$$

where

L : Rated life rev
 Ca : Basic dynamic load rating N
 Fa : Axial load N
 fw : Load factor (table 2)

Table 2 Load Factor

Vibrations/impact	Speed (V)	fW
Faint	Very low $V \leq 0.25$ m/s	1.0 to 1.2
Weak	Low $0.25 \leq V \leq 1.0$ m/s	1.2 to 1.5
Medium	Moderate $1.0 \leq V \leq 2.0$ m/s	1.5 to 2.0
Strong	High $2.0 \text{ m/s} < V$	2.0 to 3.5

Service life time

When the rated life L has been obtained, the service life time is calculated from the following equation if the stroke length and the number of reciprocations are constant.

$$Lh = \frac{L \times \ell}{2 \times \ell_s \times n_1 \times 60}$$

where

Lh : Service life time h
 ℓs : Stroke length min
 n₁ : Revolutions per minute min⁻¹
 ℓ : Lead min

MEMO

Dimensional Table for Model SBK

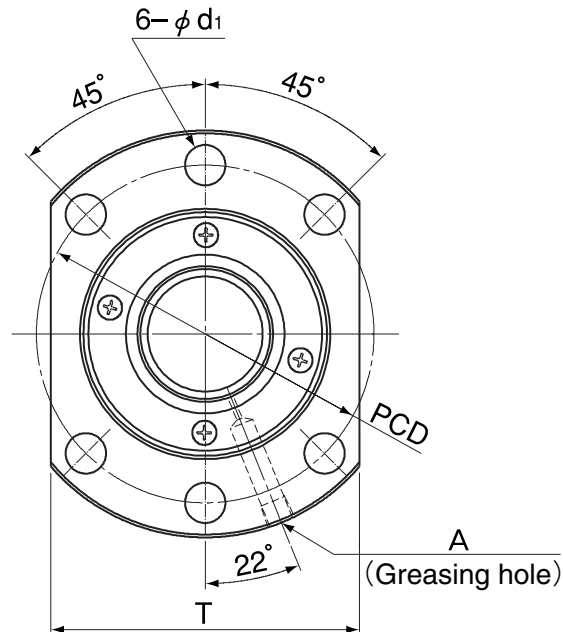

Model No.	Screw shaft outer diameter d	Lead ℓ	No. of loaded circuits Rows × turns	Ball center diameter dp	Thread minor diameter of the screw shaft dc	Basic load rating		Rigidity K (N/μm)
						Ca (kN)	Coa (kN)	
SBK3620-7.6	36	20	2×3.8	37.75	31.4	48.5	85.0	870
SBK4020-7.6	40	20	2×3.8	42.0	34.9	59.7	112.7	970
SBK4030-7.6	40	30	2×3.8	42.0	34.9	59.2	107.5	970
SBK5020-7.6	50	20	2×3.8	52.0	44.9	66.8	141.9	1170
SBK5030-7.6	50	30	2×3.8	52.0	44.9	66.5	135.0	1170
SBK5036-7.6	50	36	2×3.8	52.0	44.9	65.9	135.0	1170
SBK5520-7.6	55	20	2×3.8	57.0	49.9	69.8	156.4	1250
SBK5530-7.6	55	30	2×3.8	57.0	49.9	69.2	147.0	1250
SBK5536-7.6	55	36	2×3.8	57.0	49.9	69.1	148.7	1260

Example of model number coding

SBK3620-7.6 QZ RR G0 + 1500L C5

① ② ③ ④ ⑤ ⑥

- ① Model number
- ② With QZ Lubricator (without QZ Lubricator: no symbol)
- ③ Seal symbol (RR: labyrinth seal on both ends; WW: wiper ring on both ends)
- ④ Axial clearance symbol
- ⑤ Overall screw shaft length (in mm)
- ⑥ Accuracy symbol

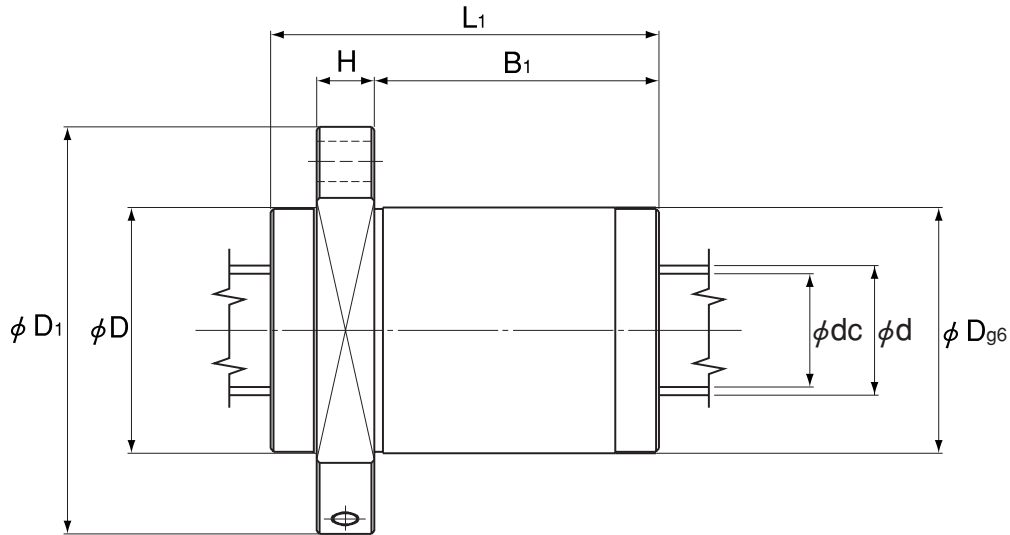

Unit: mm

Outer diameter D	Flange diameter D ₁	Overall length L ₁	Nut dimensions					Greasing hole A	Screw shaft inertial moment/mm kg · cm ² /mm	Max permissible rotation speed (min ⁻¹)
			H	B ₁	PCD	d ₁	T			
73	114	110	18	81	93	11	86	PT1/8	1.29 × 10 ⁻²	4230
80	136	110	20	79	112	14	103	PT1/8	1.97 × 10 ⁻²	3800
80	136	148	20	117	112	14	103	PT1/8	1.97 × 10 ⁻²	3800
90	146	110	22	77	122	14	110	PT1/8	4.82 × 10 ⁻²	3070
90	146	149	22	116	122	14	110	PT1/8	4.82 × 10 ⁻²	3070
90	146	172	22	139	122	14	110	PT1/8	4.82 × 10 ⁻²	3070
96	152	110	22	77	128	14	114	PT1/8	7.05 × 10 ⁻²	2800
96	152	149	22	116	128	14	114	PT1/8	7.05 × 10 ⁻²	2800
96	152	172	22	139	128	14	114	PT1/8	7.05 × 10 ⁻²	2800

Note: The rigidity values in the table represent spring constants each obtained from the load and the elastic displacement when providing a preload 10% of the basic dynamic load rating (Ca) and applying an axial load three times greater than the preload. These values do not include the rigidity of the components related to mounting the ball screw nut. Therefore, it is normally appropriate to regard roughly 80% of the value in the table as the actual value.

If the applied preload (Fa0) is not 0.1 Ca, the rigidity value (KN) is obtained from the following equation.

$$K_N = K \left(\frac{Fa_0}{0.1Ca} \right)^{\frac{1}{3}} \quad \kappa : \text{Rigidity value in the dimensional table.}$$

Options

For model SBK, two options are available to achieve long-term maintenance-free operation. Specifically, they are QZ Lubricator for Ball Screws, which contains a highly oil-impregnated fiber net, and Wiper Ring, which is a contact seal for Ball Screws highly capable of removing foreign matter.

■QZ Lubricator

QZ Lubricator is a new lubrication system capable of feeding the required amount of lubricant where it is needed.

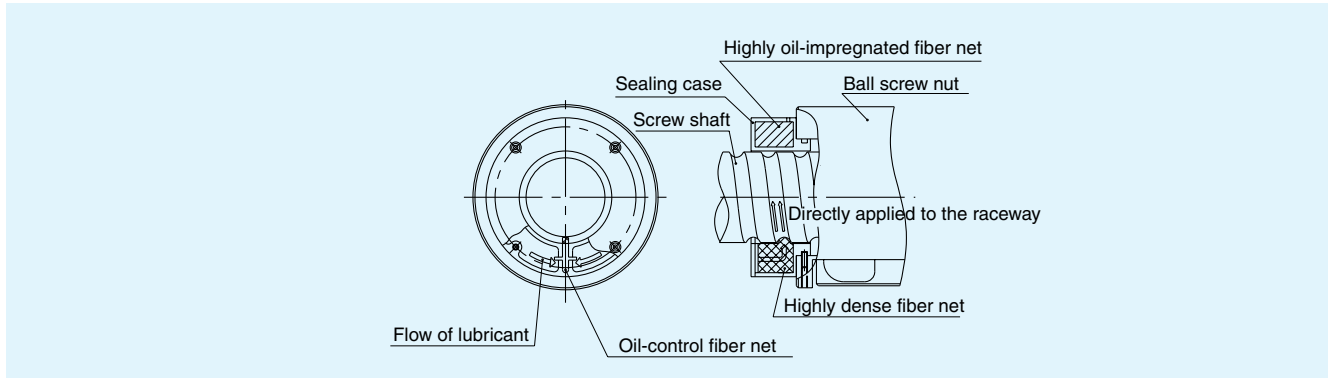

<Features>

●Maintenance interval can substantially be extended

With normal grease lubrication in a Ball Screw, a minimum amount of oil is lost as the system travels. When attached to the Ball Screw, QZ Lubricator supplements oil lost over a long period to substantially extend the maintenance interval.

●Environmentally friendly lubrication system

QZ Lubricator is an environmentally friendly lubrication system that does not waste oil since it feeds the right amount of oil to the right location through a highly dense fiber net.

●Oil settings according to the intended use can be made

With QZ Lubricator, it is possible to make settings of oil to be used according to the service environment of the Ball Screw.

■Wiper Ring

With the wiper ring, a special resin with high wear resistance elastically contacts the shaft circumference and the thread groove, and eight slits remove the foreign matter, thus to prevent foreign matter from entering the ball screw nut.

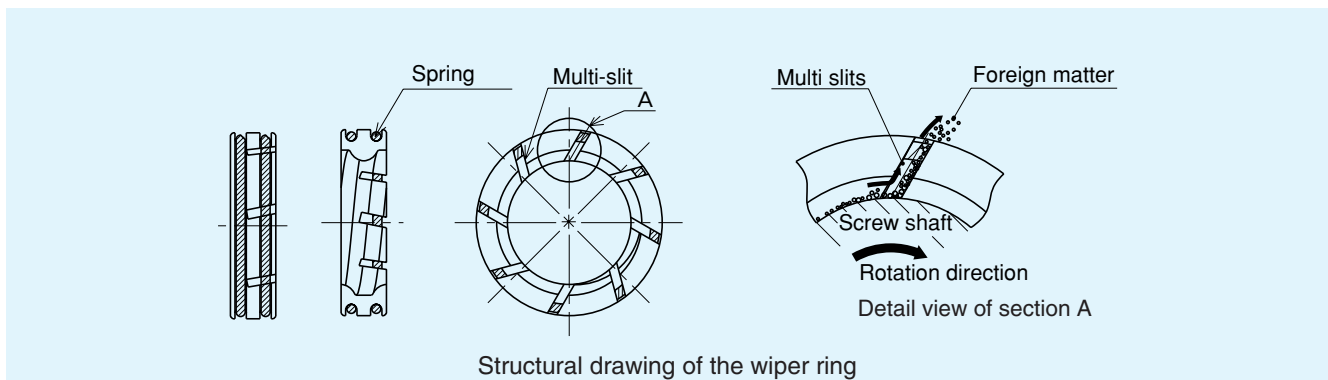

<Features>

- Prevents foreign matter from entering the ball screw nut.
- Contacts the screw shaft at a constant pressure to minimize heat generation.
- Excels in wear resistance, impact resistance and chemical resistance.
- When attached to QZ Lubricator for the Ball Screw, it significantly extends the maintenance interval even in a harsh environment.

The Ball Screw Nut Dimensions with the Wiper Ring (WW) and QZ Lubricator (QZ) Attached

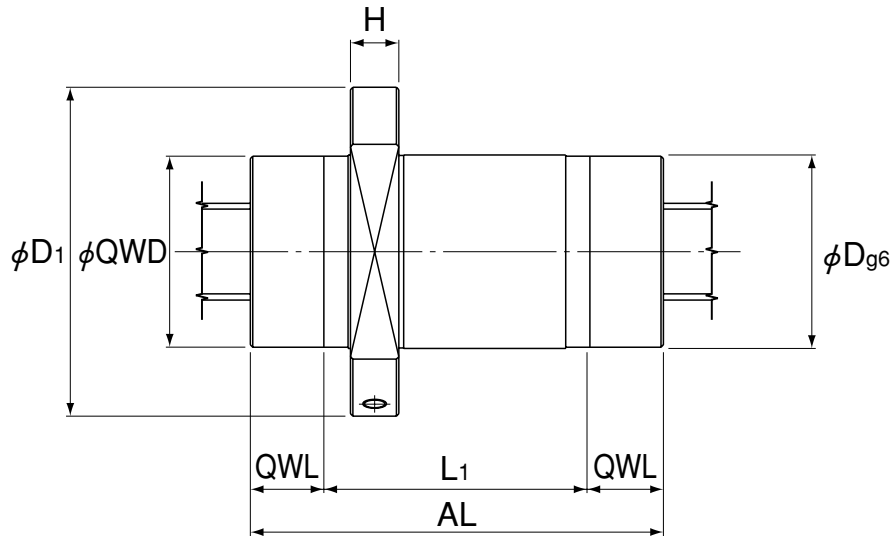

Unit: mm

Model No.	Dimensions with WW attached				Dimensions with QZWW attached		
	Length L ₁	Flange width H	Flange diameter D ₁	Outer diameter D	Length QWL	Outer diameter QWD	Overall length AL
SBK3620-7.6	110	18	114	73	38	69	186
SBK4020-7.6	110	20	136	80	40.4	79	190.8
SBK4030-7.6	148	20	136	80	40.4	79	228.8
SBK5020-7.6	110	22	146	90	45	89	200
SBK5030-7.6	149	22	146	90	45	89	239
SBK5036-7.6	172	22	146	90	45	89	262
SBK5520-7.6	110	22	152	96	42	95	194
SBK5530-7.6	149	22	152	96	42	95	233
SBK5536-7.6	172	22	152	96	42	95	256

THK Precautions on Using THK High-Speed Ball Screw with Ball Cage Model SBK

Precautions on Use

● Handling

- Disassembling components may cause dust to enter the system or degrade mounting accuracy of parts. Do not disassemble the product.
- Tilting the screw shaft and the ball screw nut may cause them to fall by their self-weights.
- Dropping or hitting the Ball Screw may damage the ball circulation section, which may cause functional loss. Giving an impact to the product could also cause damage to its function even if the product looks intact.

● Lubrication

- Thoroughly remove anti-corrosion oil and feed lubricant before using the product.
- Do not mix lubricants of different physical properties.
- In locations exposed to constant vibrations or in special environments such as clean rooms, vacuum and low/high temperature, normal lubricants may not be used. Contact THK for details.
- When planning to use a special lubricant, contact THK before using it.
- Lubrication interval varies according to the service conditions. Contact THK for details.

● Precautions on Use

- Do not remove the ball screw nut from the screw shaft. Doing so may cause the balls or the ball cage to fall off.
- Entrance of foreign matter to the ball screw nut may cause damage to the ball circulating path or functional loss. Prevent foreign matter, such as dust or cutting chips, from entering the system.
- If foreign matter adheres to the product, replenish the lubricant after cleaning the product. For the type of cleaning liquid, contact THK.
- Use a cover or the like to prevent the coolant from entering the ball screw nut.
- Do not use the product at temperature of 80°C or higher. When desiring to use the system at temperature of 80°C or higher, contact THK in advance.
- If using the product with vertical mount, the ball screw nut may fall by its self-weight. Attach a mechanism to prevent it from falling.
- Using the product at speed exceeding the permissible rotation speed may cause breakage of a component or accident. Be sure to use the product within the specification range designated by THK.
- Forcibly driving in the screw shaft or the ball screw nut may cause an indentation on the raceway. Use care when mounting components.
- If an offset or skewing occurs with the ball screw shaft support and the ball screw nut, it may substantially shorten the service life. Pay much attention to components to be mounted and to the mounting accuracy.
- When using the product in locations exposed to constant vibrations or in special environments such as clean rooms, vacuum and low/high temperature, contact THK in advance.
- Letting the ball screw nut overrun will cause balls to fall off or the ball-circulating component to be damaged. Be sure not to let it overrun.

● Storage

When storing the Ball Screw, enclose it in a package designated by THK and store it in a horizontal orientation while avoiding high temperature, low temperature and high humidity.

● “LM Guide,” “Ball Cage,” “,” and “QZ” are registered trademarks of THK CO., LTD.

- The photo may differ slightly in appearance from the actual product.
 - The appearance and specifications of the product are subject to change without notice. Contact THK before placing an order.
 - Although great care has been taken in the production of this catalog, THK will not take any responsibility for damage resulting from typographical errors or omissions.
 - For the export of our products or technologies and for the sale for exports, THK in principle complies with the foreign exchange law and the Foreign Exchange and Foreign Trade Control Law as well as other relevant laws.
- For export of THK products as single items, contact THK in advance.

THK CO., LTD.

HEAD OFFICE 3-11-6, NISHI-GOTANDA, SHINAGAWA-KU, TOKYO 141-8503 JAPAN
ASIA PACIFIC SALES DEPARTMENT PHONE:(03)5434-0351 FAX:(03)5434-0353

CHINA

BEIJING

PHONE:(10)6590-3557 FAX:(10)6590-3557

THK SHANGHAI CO., LTD.

PHONE:(21)6334-5131 FAX:(21)6334-5137

THK SHOUZAN CO.,LTD.

PHONE:2376-1091 FAX:2376-0749

TAIWAN

TAIPEI

PHONE:(02)2888-3818 FAX:(02)2888-3819

TAICHUNG

PHONE:(04)2359-1505 FAX:(04)2359-1506

SOUTHERN

PHONE:(06)289-7668 FAX:(06)289-7669

KOREA (SEOUL)

PHONE:(02)3463-0351 FAX:(02)3017-0351

MALAYSIA (KUALA LUMPUR)

PHONE:(03)9287-1137 FAX:(03)9287-8071

INDIA (BANGALORE)

PHONE:(080)330-1524 FAX:(080)330-1524

NORTH AMERICA

CHICAGO

PHONE:(847)310-1111 FAX:(847)310-1182

NEW JERSEY

PHONE:(201)529-1950 FAX:(201)529-1962

ATLANTA

PHONE:(770)840-7990 FAX:(770)840-7897

LOS ANGELES

PHONE:(714)891-6752 FAX:(714)894-9315

SAN FRANCISCO

PHONE:(925)455-8948 FAX:(925)455-8965

BOSTON

PHONE:(781)575-1151 FAX:(781)575-9295

DETROIT

PHONE:(248)858-9330 FAX:(248)858-9455

TORONTO

PHONE:(905)712-2922 FAX:(905)712-2925

BRASIL (SÃO PAULO)

PHONE:(011)3767-0100 FAX:(011)3767-0101

EUROPE

DÜSSELDORF

PHONE:0049-(0)2102-7425-0 FAX:0049-(0)2102-7425-299

STUTTGART

PHONE:0049-(0)7150-9199-0 FAX:0049-(0)7150-9199-888

MÜNCHEN

PHONE:0049-(0)89-370616-0 FAX:0049-(0)89-370616-26

U.K.

PHONE:0044-(0)1908-303050 FAX:0044-(0)1908-303070

MILANO

PHONE:0039-039-2842079 FAX:0039-039-2842527

BOLOGNA

PHONE:0039-051-6412211 FAX:0039-051-6412230

SWEDEN

PHONE:0046-(0)8-4457630 FAX:0046-(0)8-4457639

AUSTRIA

PHONE:0043-(0)7229-51400 FAX:0043-(0)7229-51400-79

SPAIN

PHONE:0034-93-652-5740 FAX:0034-93-652-5746

THK FRANCE S. A. S.

PHONE:0033-(0)4-37491400 FAX:0033-(0)4-37491401

SOUTH AFRICA

PHONE:0027-(0)44-2720020 FAX:0027-(0)44-2720020